

ACCESSORIES

SAMMYS TOGGLE™

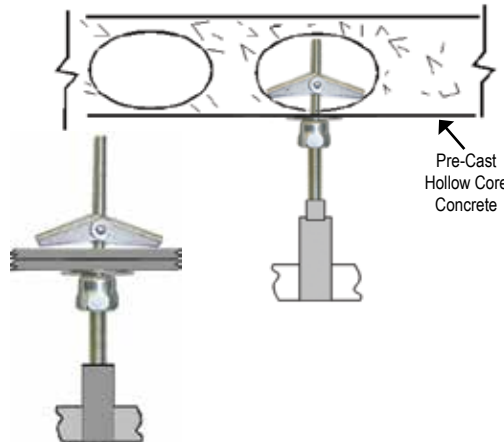

Application



Installation Steps

1. Pre-drill a 5/8" hole with a regular drill or hole saw.
2. Insert SST screw into #14 black nut driver. With wing nut and washer on bolt, insert wing nut through surface, and begin installation.
3. When bolt is secure and nut driver spins free, stop drill motor and remove.
4. SST screw is now ready to receive 1/4", 3/8", or Metric all thread rod or bolt stock.



#14 Black
Nut Driver
Part # 8113910

Rod Size	Part Number	Model	Screw Descriptions	Ultimate Pullout (lbs)	Box Qty	Case Qty
3/8"	8064925	SST 30	1/4 x 3"	450 (Lath & Plaster) 404 (2 Layers 5/8 Rock)	25	125

DEKTITE® PIPE FLASHING



Application

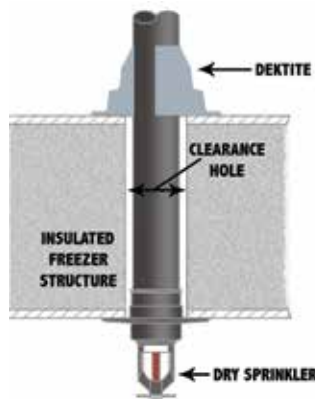

**STAY UP TO
CODE!**
with a quicker,
more efficient way
to flash your
refrigeration/freezer units.

Product Features

- Complies with NFPA 13 Code Changes.
- Flashing for dry pendant sprinklers subject to extreme temperature changes.
- One piece construction is easy to install.
- Pipe diameter markings ensure accurate fit.
- EPDM temperature range of -65°F to +250°F.

Part Number	Description	Pipe Outside Diameter	Dektite Base Diameter	Dektite Height	Box Qty
4003910	1	1/4" - 2"	4-3/4"	3"	10
4004910	2	1-3/4" - 3-1/4"	6-1/4"	4"	10